

SEA FROST®

BD SPEED CONTROL (with AEO function) (For XP & XPX compressors)

This single knob control is for installation with an existing thermostat.

Installation

Mount the BD Speed Control panel in a dry area. It can be panel mounted or can be installed into a surface mount box.

The speed control has red LEDs indicating the compressor is running and at what speed. Be sure it is easy to view. . Mount with the 4 #6 flat head screws provided.

The BD Speed Control panel has a 15 foot 4 wire harness. These wires may be cut or spliced as needed. If you are splicing be sure to maintain the color code. The harness wires connect to the BD compressor module.

Wiring

Disconnect one of the power cables, pull the fuse, or turn off power while making the wiring changes. Refer to the wiring drawing on page 9 of the BD manual.

[] Crimp a female connector (provided) to the red wire from the speed control cable and plug it into + (3rd row from top) terminal. This is the row with the fan red wire connected and is the last open connector. (An additional + terminal is located just above this row to right of Seafrost logo.)

[] Crimp a female connector to the black wire from the speed control cable. Plug this connector into F terminal row on the module. Connect to either open connector.

[] Cut out jumper in the T row on the electronic module. Crimp a female connector to the ends of both the green and white wires from the speed control. The white and green wires from the speed control will be attached to same terminals from which the jumper was removed. From left to right it is terminal 1 and terminal 2 in row T. There is no polarity.

Operation

There are four positions AEO, high, medium and low. Refer to your XP manual for AEO operating features.

BD SPEED CONTROL WIRING DIAGRAM (with AEO function)
(For XP & XPX compressors)

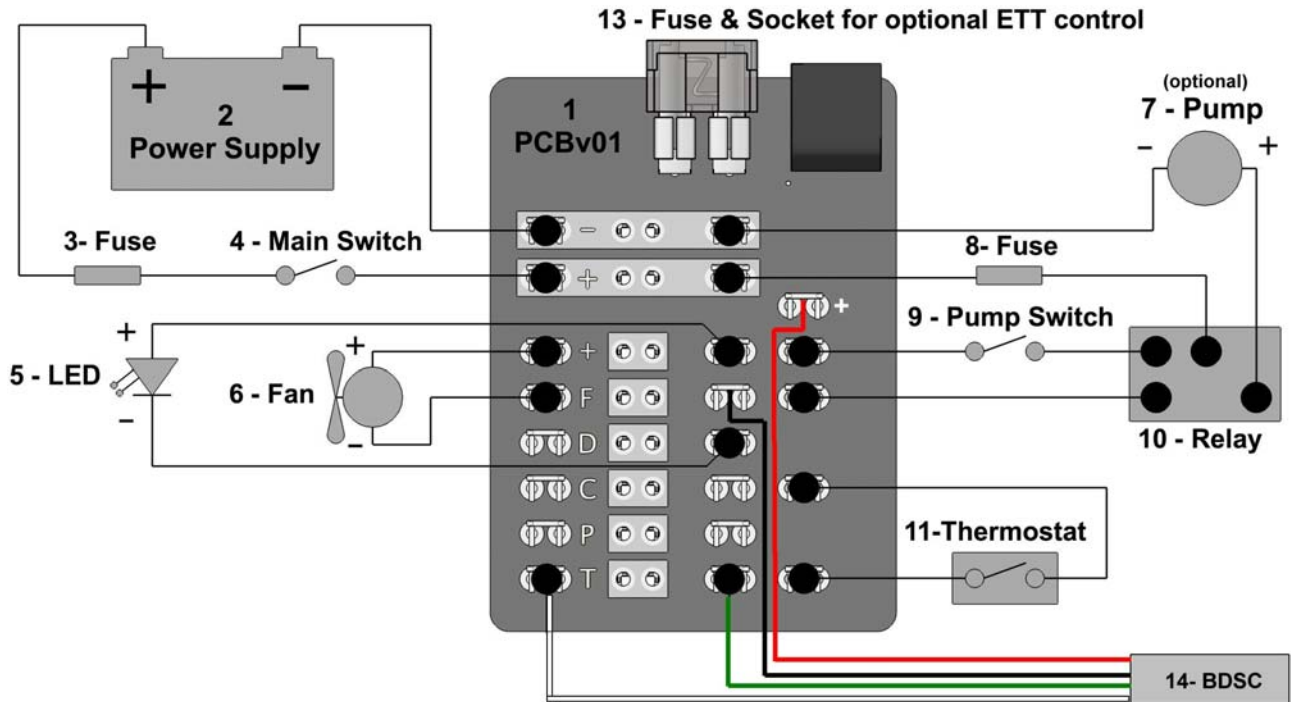

NOTE: When using the modular thermostat connection (#13) there are no connections on thermostat terminals (#11).

<p>1. Electronic unit 2. Battery 3. Fuse (see electrical connections) 4. Main switch (optional) 5. LED for operational errors 6. Fan 7. Pump (For water cooled units) 8. Fuse (For water cooled units)</p>	<p>9. Pump Switch (For water cooled units) 10. Relay (For water cooled units) 11. Thermostat 12. Removed - Jumper for AEO Module 13. RJ45 jack for optional Electronic Thermostat. 14. BDSC-AEO Speed Control</p>
---	--

Note: Numbers 7, 8, 9 & 10 are for Compressor Units with the water-cooling options.