



MARCH PUMPS

1819 PICKWICK AVE., GLENVIEW, IL 60026-1306, U.S.A
 PHONE: (847) 729-5300 - FAX: (847) 729-7062
 WWW.MARCHPUMP.COM

INSTRUCTIONS & REPAIR PARTS FOR MODEL LC-3CP-MD PUMP



MODEL LC-3CP-MD
 ASS'Y NO. 0130-0091-0500

RATINGS AND SPECIFICATIONS

MODEL NO.	CONNECTORS		H.P.	ELECTRICAL		G.P.H. AT LISTED HEAD						MAX. HEAD	P.S.I. GAGE	DIMENSIONS			PACK WT.
	Inlet	Outlet		Watts	Amps	1 Ft.	3 Ft.	5 Ft.	6 Ft.	12 Ft.	18 Ft.			Ht.	Wd.	Lg.	
LC-3CP-MD	¾" FPT	½ MPT ¾ O.D.	1/20	120	2.35	510	490	405	385	180	120	19.5 Ft.	8.5	4¾	4¼	7¼	6.5 lbs.

PUMP CONSTRUCTION AND SERVICING

March "Orbital" Magnetic Drive Pumps eliminate the conventional shaft seals found in most pumps. This means that there is no rotating seal to wear and allow the liquid being pumped to leak out. In addition to this unique "seal-less" design, the pump is hermetically encapsulated in epoxy. This epoxy encapsulation now allows the pumps to be run fully submerged in many liquids. The model LC-3CP-MD pump can be run totally submerged or can be run in open air for complete moisture protection.

All these pumps can be serviced with the use of a screwdriver. The only moving parts in the pump other than the motor, is the Impeller-Magnet Assembly. This Impeller-Magnet Assembly rotates on a stationary spindle and up against a thrust washer. This is the only part that can wear out, and may need to be replaced. See the Repair Parts List for replacement parts if necessary.

ELECTRICAL CONNECTIONS AND RUNNING DRY

All models are standard in 115 Volt, 60 Hz, 1 phase A.C. All cords set are U.L. approved 18/3 wire SJT plastic cords. Standard cord length is 6 feet. 230 Volt 50 Hz and 230 Volt 60 Hz also available.

We rely on the liquid being pumped to lubricate the Impeller-Magnet Assembly spinning on the stationary spindle. If the pump is run dry for longer than 60 seconds, the plastic may "freeze" onto the spindle.

PUMP MATERIALS

All Screws are type 18-8 stainless steel.
 All "O" Ring Gaskets are Buna N Rubber.
 Stationary Spindle is Ceramic.
 Motor Bracket is Polysulfone Plastic.
 Pump Housing, Cover, and Impeller are Glass Filled Polypropylene.
 Thrust Washer is Ceramic.
 The LC model has a cupric nickel tube embedded into the epoxy to remove heat from the motor. A type 316 stainless steel tube is available on special order.

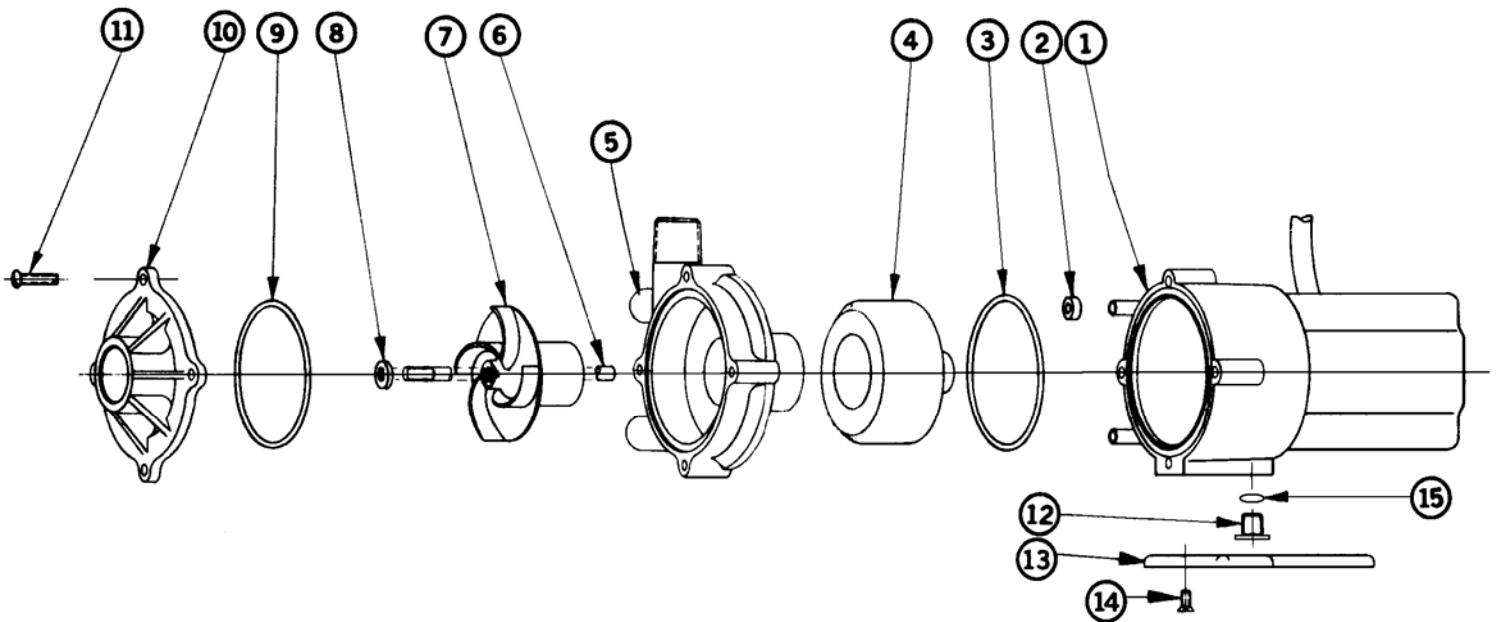

MODEL LC-3CP-MD REPAIR PARTS LIST			
ITEM	DESCRIPTION	QTY.	PART NO.
1	L.C. Epoxy Motor, Bracket, Cord Assembly, 115 Volt	1	0130-0091-0200
2	Cooling Tube Seal, Neoprene Rubber	2	0125-0007-1000
3	Bracket "O" Ring, Buna "N" Rubber	1	0130-0025-1000
4	Drive Magnet Assembly	1	0130-0043-0100
5	Pump Housing Assembly	1	0130-0019-0100
6	Shaft, Ceramic	1	0130-0024-1000
7	Impeller Assembly	1	0130-0020-0100
8	Thrust Washer, Ceramic	1	0130-0028-1000
9	Cover "O" Ring, Buna "N" Rubber	1	0130-0011-1000
10	Cover	1	0130-0021-1000
11	Screw	4	0823-0008-1000
12	Bracket Plug	1	0125-0110-1000
13a	Pump Mounting Base	1	0125-0037-1000
13b	Marine Mounting Base w/Grommets	1	0125-0113-0100
14	Base Screws	2	0130-0132-1000
15	"O" Ring	1	0210-0008-1000

Contact factory for other materials and/or parts not listed.

LIMITED WARRANTY

March pumps are guaranteed only against defects in workmanship or materials for a period of one year from date of manufacture pumping water. On all other solutions, contact the factory for application assistance. March Pump Application Worksheet 750-130-10 is available for additional warranty information.