



MARCH PUMPS

1819 PICKWICK AVE., GLENVIEW, IL 60026-1306, U.S.A
PHONE: (847) 729-5300 - FAX: (847) 729-7062
WWW.MARCHPUMP.COM

INSTRUCTIONS & REPAIR PARTS FOR MODEL 809 SERIES "MAGNE-BOOST" HOT WATER PUMP

DESCRIPTION: Your March hot water booster pump is a non-self priming unit build to handle liquid transfer in heating and cooling operations. Applications include home heating systems, solar heating systems, heat recovery systems and recirculating water in domestic and commercial hot water tanks.

Contact the factory for applications other than those listed, and for liquids other than water.

SPECIFICATIONS		
INLET AND OUTLET CONNECTIONS:		½" MPT or 5/8 Flare Tube Conn. Or Center Inlet Style
ELECTRICAL:	809	115 Volts, 60 Hz, 1 Phase, 30 Watts, 0.3 Amps, 1600 RPM, 1/100 HP
	809 HS	115 Volts, 60 Hz, 1 Phase, 80 Watts, 1.2 Amps, 3400 RPM, 1/25 HP
	809 HS-815	115 Volts, 60 Hz, 1 Phase, 85 Watts, 1.4 Amps, 3400 RPM, 1/25 HP
MAXIMUM LIQUID TEMPERATURE:		250°F
CONSTRUCTION:		Bronze, Stainless Steel, Ryton Plastic
DIMENSIONS:		Height over Threads 4-7/8" Width 3-3/8" Length w/1600 RPM Mtr. 6-1/2" Length w/3400 RPM Mtr. 7-1/2"
CAPACITY:	809	1600 RPM 3.1 GPM Maximum and 1.8 PSI Maximum
	809 HS	3400 RPM 5.3 GPM Maximum and 5.0 PSI Maximum
	809 HS-815	3400 RPM 5.5 GPM and 6.53 PSI Maximum
APPROVAL:		Motors are U.L. Yellow Card listed, impedance protected or thermal overload Protected. Complete pump under U.L. file E80954.

*UL recognition on pumps, file E80954, is for water only.

INSTALLATIONS: The 809 Series pump is assembled and ready for installation. The pump should be mounted with the Electric Conduit Box (Item 15) on the bottom. The oil ports will then be on the top of the motor. The pump housing should be installed with the arrow on our housing pointing in the direction of the water flow within the system. If the arrow indicating water flow is not in the direction you require when the motor is in position, remove the four round housing screws (Item 1) holding the housing to the motor assembly and rotate the housing assembly as required. Replace the four screws and tighten.

The pump is made up of two basic sub-assemblies. They are the Wet End Assembly (Items 1-10); and the Drive Magnet, Bracket and Motor Assembly (Items 11-15). To separate the 2 assemblies, simply remove the 4 round head screws (Item 1). The pump will then separate into the 2 sub-assemblies. The water will still be contained within the Wet End assembly unless you loosen the screws (Item 10) on the rear of the Wet End assembly.

LUBRICATION: The motor should be oiled at least once a year at the start of the heating season with 4 or 5 drops of SAE 20 weight non-detergent oil in each bearing. If the pump is used year around it should be oiled every six months. Do not over oil. No oiling is required on the ball bearing motors.

GENERAL SAFETY INFORMATION: Follow all local electrical and safety codes, and the Occupational Safety and Health Act (OSHA). Make certain that the power source conforms to the requirements of your equipment. Always disconnect power source before performing any work on or near the electric motor. Caution must be exercised to relieve any pressure in the system and in draining hot water from the pump or the system.

DISASSEMBLY AND REASSEMBLY:

- 1—The motor assembly (Item 15) can be removed from the Wet End assembly without having to drain the liquid out of the system.
- 2—Remove four screws (Item 1) and slide the motor assembly away from the Wet End assembly.
- 3—If you must replace parts inside the pump housing assembly, then first close off the valves that supply water to the heating system or to the hot water tank. Drain the system to relieve any pressure.
- 4—After the system is drained and cool enough to handle, then remove the four screws (Item 10) on the rear of the housing.
- 5—The impeller magnet housing (Item 9) can now be removed. It may be snug fit into the pump housing and it may be necessary to pry evenly, under the four ears to loosen it.
- 6—Remaining pump parts can now be lifted out in sequence as shown on the exploded view. Replace any worn or damaged parts. Replace the "O" ring (Item 3) anytime the impeller magnet housing is removed.

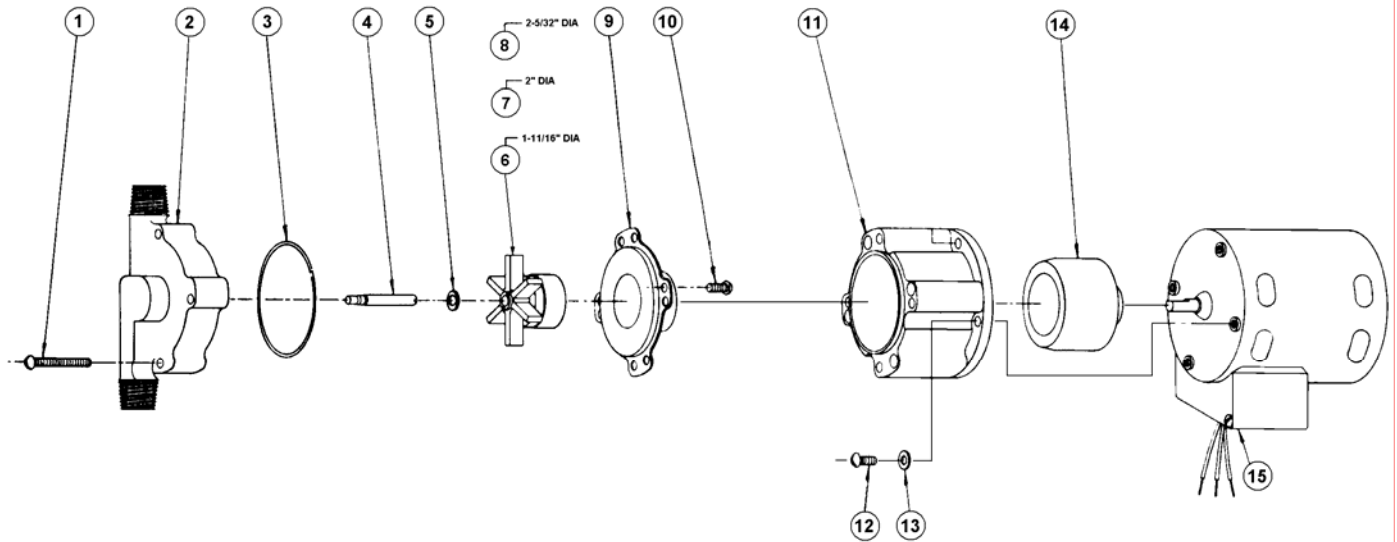

Note: Pumps with 12 and 24 volt motors are available.
Contact the factory for more information.

REPAIR PARTS LIST			
ITEM	DESCRIPTION	QTY.	PART NO.
1	#8 x 1-1/4 Long Rd. Hd. Screw	4	0923-0003-1000
2a	Pump Housing w/1/2" MPT	1	0809-0013-0000
2b	Pump Housing w/Center Inlet Style*	1	0809-0142-0000
2c	Pump Housing Plastic w/1/2" MPT*	1	0809-0079-1000
3a	"O" Ring, Silicon Rubber, used in bronze housing (2a & b)	1	0809-0165-1000
3b	"O" Ring, Silicon Rubber, used in plastic housing (2c)	1	0809-0027-1000
4a	Impeller Shaft w/Thread	1	0809-0008-1000
4b	Impeller Shaft w/"D" Flat	1	0809-0161-1000
5	Thrust Washer	1	0809-0043-1000
6	Impeller & Magnet Assembly 1-11/16 Dia. (3400 RPM) 809 HS	1	0809-0005-0200
7	Impeller & Magnet Assembly 2 Dia. (1600 RPM) 809	1	0809-0005-0100
8	Impeller & Magnet Assembly 2-5/32 Dia. (3400 RPM) 815	1	0809-0107-0200
9	Impeller Magnet Housing	1	0809-0012-1000
10	#8 x 3/8 Long Rd. Hd. Screw	4	0135-0040-1000
11	Connecting Bracket	1	0809-0058-1000
12	#8 x 3/8 Long Rd. Hd. Screw	4	0135-0040-1000
13	#8 Flat Washer	4	0858-0004-1000
14	Drive Magnet Assembly	1	0125-0083-0100
15a	Motor, 115 Volt, 1600 RPM	1	0809-0064-1000
15b	Motor, 115 Volt, 3400 RPM	1	0809-0090-1000

* Old Style Housings Require Threaded Imp. Shaft (4a)
New Housings Require Round Imp. Shaft with "D" Flat (4b)

LIMITED WARRANTY

March pumps are guaranteed only against defects in workmanship or materials for a period of one year from date of manufacture pumping water. On all other solutions, contact the factory for application assistance. March Pump Application Worksheet 750-130-10 is available for additional warranty information.