

DC 5000 MOTOR AND WATER PUMP MAINTENANCE

Lubrication

The DC 5000 motor and the March water pump are supplied with lifetime lubricated ball bearings.

Brushes (Leeson Motor)

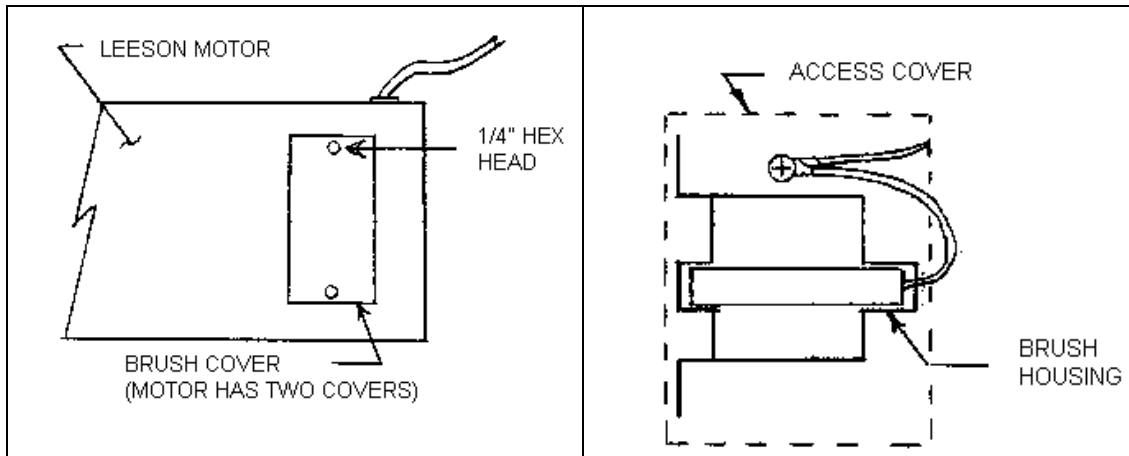

Motor brushes need periodic inspection and replacement as wear indicates. Brush wear is greatly influenced by individual application, voltage and heat load. It is recommended that brush wear be checked at early intervals of operation in order to determine future required inspection.

With **daily** use of the DC 5000 as a primary system make an initial inspection of the brushes after:

Single plate refrigerator	6 months
Multi-plate system with freezer	3 months

Standard Leeson brushes have an initial length of $1 \frac{1}{4}$ ". When brushes are worn to a length of $\frac{5}{8}$ " they and the brush springs should be replaced. **Operation of a motor with brushes shorter than this will cause the brushes to jam in the brush housing, arcing and wearing the commutator. A worn or damaged commutator will accelerate brush wear and further damage your motor.** It is normal for one brush to wear more than the other. Check them both.

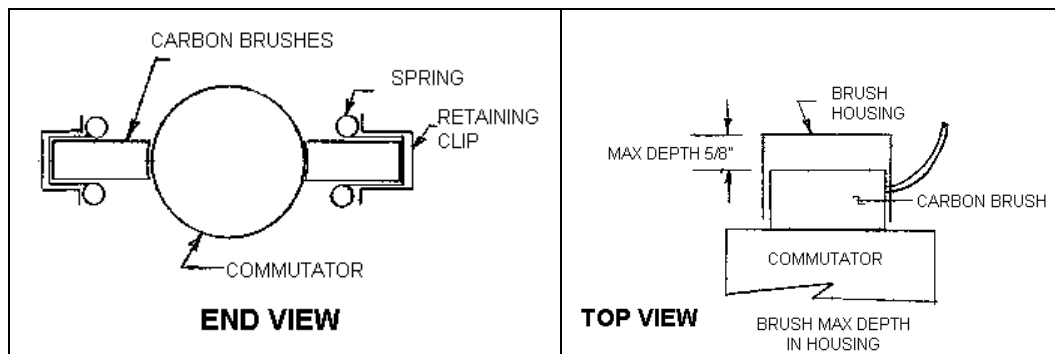

Tip: In a new motor with new brushes the back of the brush will be flush with the brush housing, as the brush wears the distance into the housing will increase. (See top view drawing below.) A quick measurement of the depth will be sufficient. When the brush is $\frac{5}{8}$ " into the holder it will need replacement. If in doubt change the brushes. Carry spares.

When changing brushes, be sure the Phillips screw holding the brush wire **and power** lead is tightened properly to assure a good electrical connection.

Commutator wear can be measured by installing new brushes and measuring the depth in the housing. A properly maintained motor will show little wear here (brush end flush with the housing). A worn commutator may need to be resurfaced to prevent excessive and rapid wear of replacement brushes.

March Water Pump

The water pump motor brushes are $\frac{7}{16}$ " when new. Replace them before the spring becomes close enough to damage the commutator.